

Super Market Light

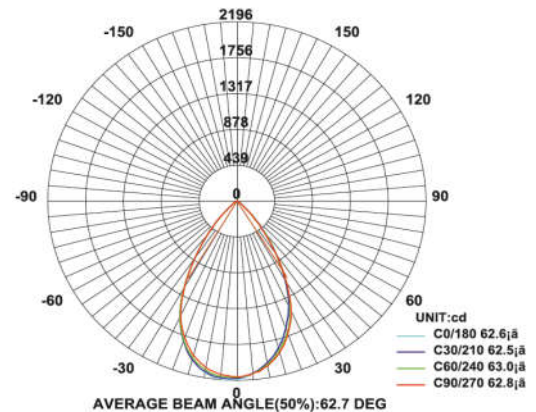
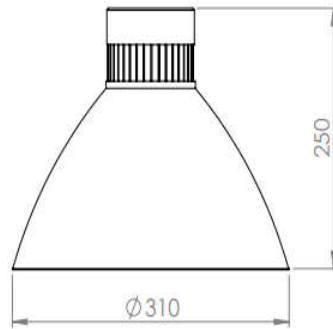

Model: iLED 50 DS 21G 01

PRODUCT DESCRIPTION

The super market suspended/angular mount luminaires are in the range of 36 W, 40W and 50 W. Universal power supply/drivers with input range of 90 V to 305 V AC 50/60 Hz and PF >0.95. The material used is Extrusion aluminum with reflective hood and milky diffuser. It is ideal for factory, warehouse, yard, super market GREEN FOR VEGITABLES & etc.

Different fixture colours available on request.

SPECIFICATION

Material	: Extrusion aluminum with reflective hood and milky diffuser
Lumen Efficacy	: 160 – 180 lumens
Mounting	: Suspended
Power	: 50W
Voltage	: 90 V to 305 V AC 50/60 Hz
Power Factor	: >0.95
LED colors	: White 6000-6400 K Neutral White 4000-4500 K Warm White 2700-3000 K
Lumen Flux	: 120-140 lm/W
Dimension	: D-245 X H-260 mm
Driver	: Internal
Operating Temp	: -40°C ~ + 70°C
CRI	: 85
IP Rating	: IP 20
Led used	: CREE ⇄
Dimmable Interface	: CASAMBI , Colour tunable (2700 K – 6000 K), DALI, Edge pulse/0/1-10 V dimming control (optional)

ORDERING INFORMATION

iLED	50	DS	01	W	WW	NW
Brand name	Rated Power	Departmental Store	Model No.	White	Warm White	Neutral White

The technical specifications may vary due to continuous improvement without prior notice.

*Logos of products and companies are used for reference

www.iled.in

iLED Lighting Systems Pvt Ltd
Chennai, Tamil Nadu, India 600096